

# A-43 High Integrity Container

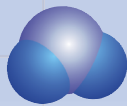

## Industrial Water Division

Advanced Technologies for Packaging Difficult Solid Waste

### A-43 HIC

*The A-43 High Integrity Container was specifically designed for packaging dross, abrasive water jet grit, filters and other waste materials containing irradiated metals.*

All packaging activities associated with the A-43, including dewatering and HIC Closure, take place underwater, thereby minimizing personnel exposure and the potential for airborne contamination. Additional features of this proven and innovative process container are as follows:

#### FEATURES

- ✓ SC-DHEC Certificate of Compliance
- ✓ Accommodates Waste to 10,000+ R/Hr
- ✓ Remote / Submersed Operation
- ✓ Remote Lid Closure
- ✓ Metallic High Alloy Construction
- ✓ ASME Section VIII Code Design
- ✓ Safe Long Term Storage / Fire Proof
- ✓ Physical Dimensions Compatible with TN-RAM
- ✓ Secondary Lid For Lifting and Protection of Primary Lid Connections

#### BENEFITS

- ✓ ALARA
  - Minimizes Personnel Exposure
  - Mitigates Potential for Leakage and Spills
  - Mitigates Potential for Airborne Contamination
  - No Air Picks Required for Cask Loading
- ✓ Simplifies Handling of Very High Rad Materials
- ✓ Negates Need for Shielding
- ✓ Minimizes Floor Space
- ✓ Shortens Hose Runs



USA  
AVANTECH INCORPORATED  
1800, SOUTH CAROLINA 29063  
GROSS WEIGHT, 9,200 LBS.  
  
EMPTY WT. 2,900  
EMPTY WT. W/O CLOSURE LID, 2,700  
DATE OF MFG. 6-8-00  
SERIAL NO. 9909-3A40-0600-03  
  
LINER I.D. A-43 PROCESS HIC



QUALITY SOLUTIONS to your waste treatment problems

803-407-7171  [www.avantechinc.com](http://www.avantechinc.com)  [info@avantechinc.com](mailto:info@avantechinc.com)

# A-43 High Integrity Container

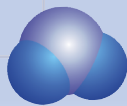

## Industrial Water Division

Advanced Technologies for Packaging Difficult Solid Waste

# A-43 HIC

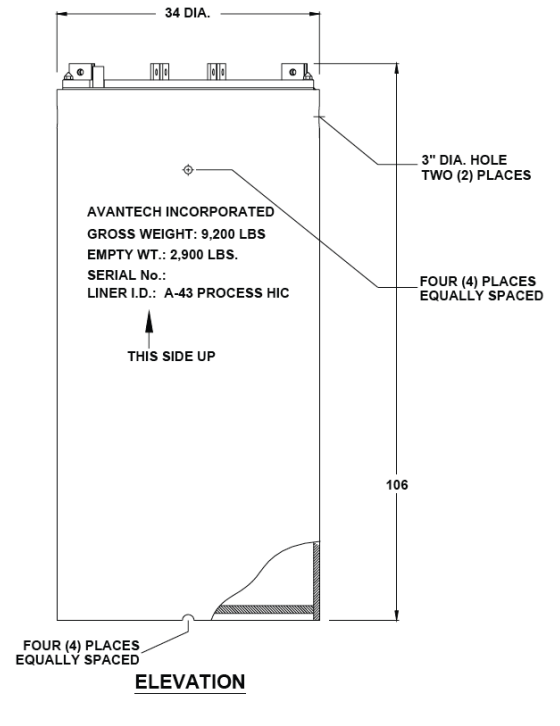
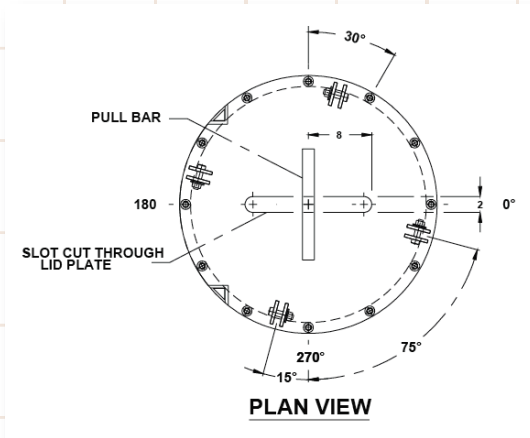

### SPECIFICATIONS\*

Model No.	Avantech A-43
Weight (empty)	2,700 lbs.
Weight (full)	9,200 lbs. (max)
Max. Waste Vol.	42.5 Cu-Ft.
Disposal Vol.	55.8 Cu-Ft.
Outside Diameter	34 in.
Overall Height	106 in.
Operating Pres.	50 psig to Full Vacuum
Connection Size	1" (Typ.)

\* Typical specifications, may vary per application

### STANDARD OPTIONS

Wastewater Treatment Rate 15 gpm

### AVAILABLE OPTIONS

- ✓ Backwashable Internals
- ✓ Multimedia Internals
- ✓ Filtration
- ✓ Ultrasonic Fuel solids removal

**South Carolina Office** ■ 132 Harbison Blvd - Suite 302 ■ Columbia, SC 29212  
 Jim Braun ■ 803.407.7171 x203 ■ 803.407.1215 Fax ■ jbraun@avantechinc.com

**Tennessee Office** ■ 1000 Commerce Park Drive ■ Oak Ridge, TN 37922  
 Tracy Barker ■ 865.482.8433 ■ 865.482.2021 Fax ■ tbarker@avantechinc.com



QUALITY SOLUTIONS to your waste treatment problems

803-407-7171 ■ www.avantechinc.com ■ info@avantechinc.com